

Pit Plan

	REACTIONS	
	STATIC	DYNAMIC
P1	1000 kg	
P2	900 kg	1800 kg
P3	450 kg	

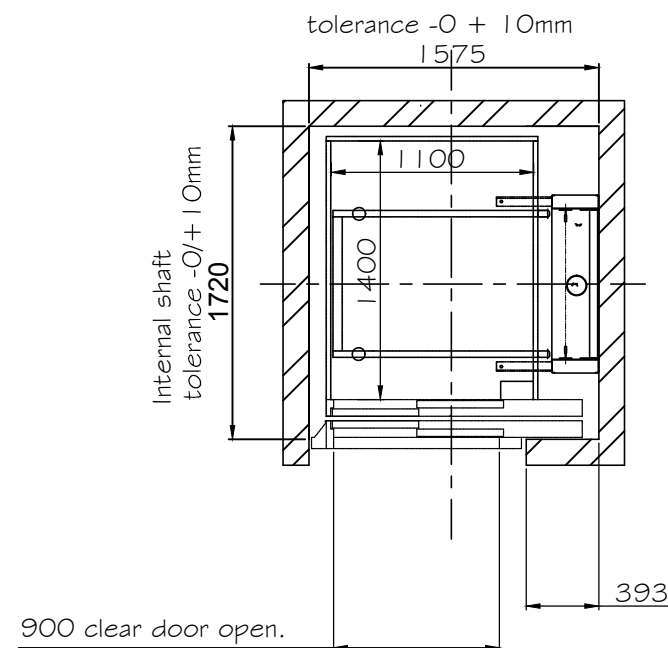

Well Plan

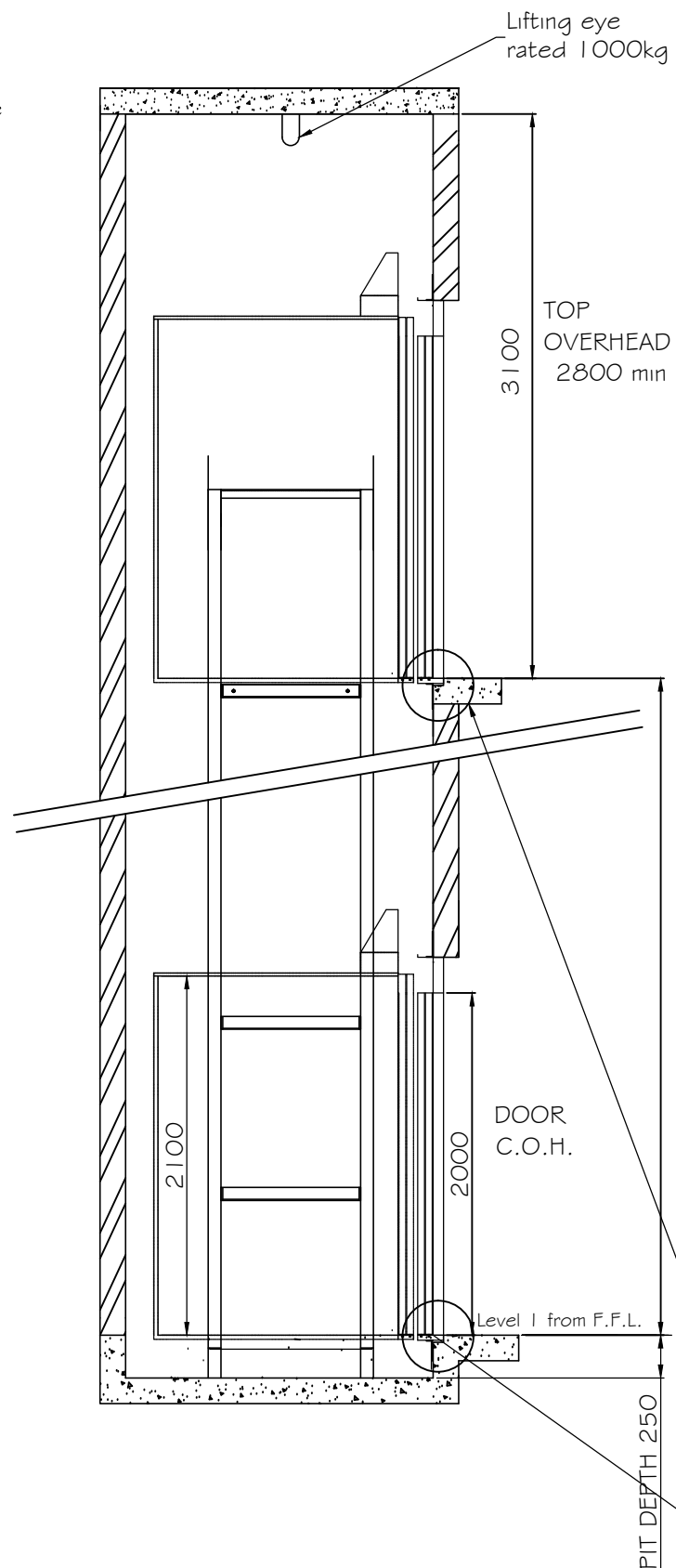

Section thru shaft

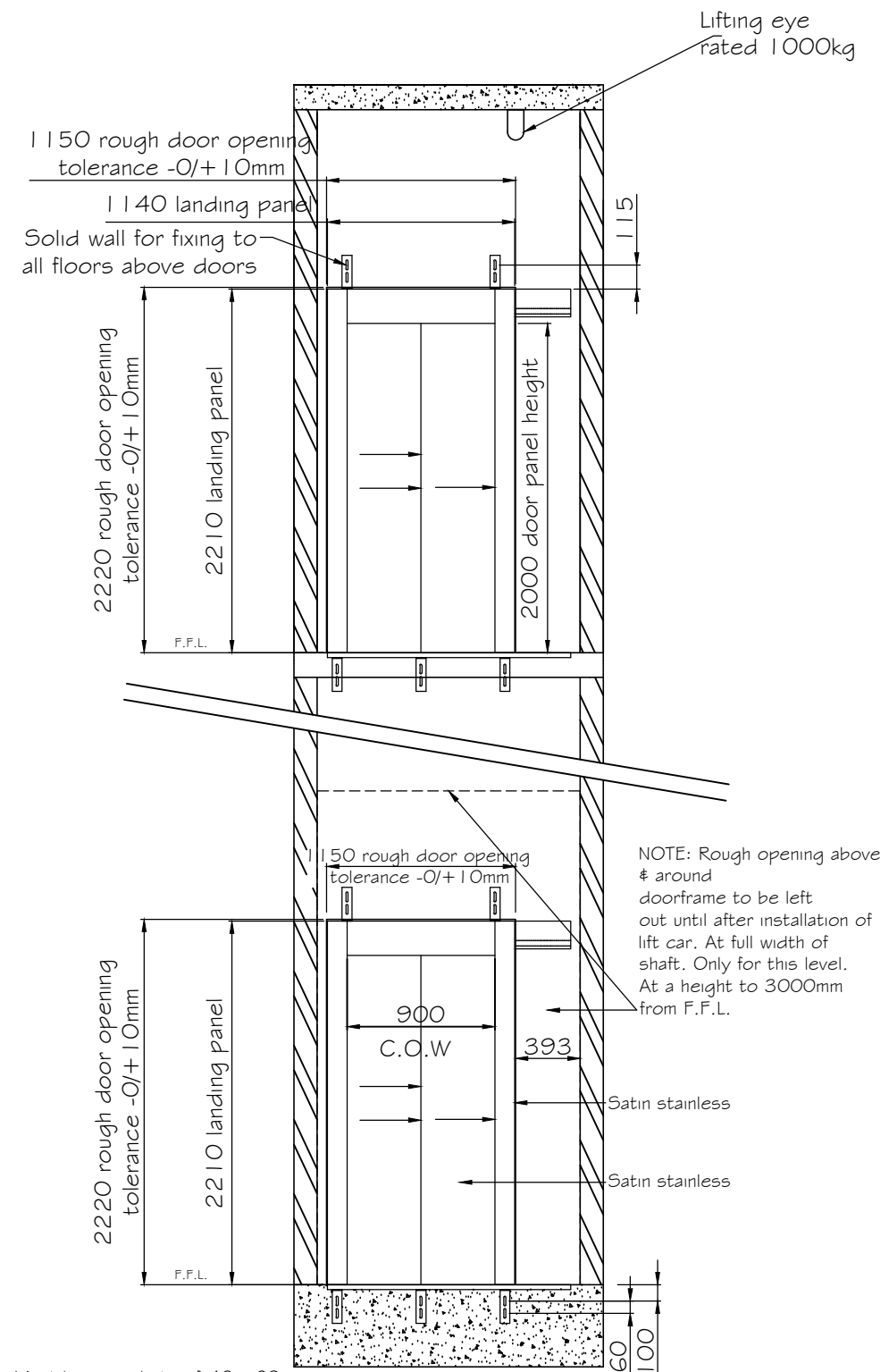

Must have a rebate of 42 x 60mm at sill level on all floors

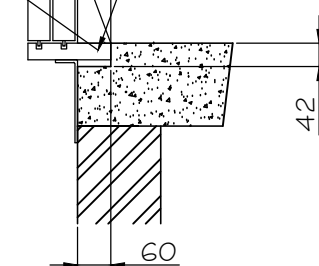

Scale	N.T.S.	
Date	22/01/16	Original issue
Issue	0	Remarks

HARWEL LIFTS	
Layout Drawing for Model HWLR Passenger Lift shaft by others	Drawing No NO117-0